

PENRHOS COLLEGE

STRIVE FOR THE HIGHEST

YEAR 12 PHYSICS

SEMESTER TWO EXAM

2011

Name _____

Mark _____ /

Time allowed for this paper

Reading time before commencing work: ten minutes

Working time for paper: three hours

Materials required/recommended for this paper

To be provided by the supervisor

This Question/Answer Booklet

Formulae and Constants Sheet

To be provided by the candidate

Standard items: pens, pencils, eraser, correction fluid, ruler, highlighters

Special items: non-programmable calculators satisfying the conditions set by the Curriculum Council for this course

Important note to candidates

No other items may be taken into the examination room. It is **your** responsibility to ensure that you do not have any unauthorised notes or other items of a non-personal nature in the examination room. If you have any unauthorised material with you, hand it to the supervisor **before** reading any further.

Structure of this paper

Section	Number of questions available	Number of questions to be answered	Suggested working time (minutes)	Marks available	Percentage of exam
Section One: Short response	13	13	50	56	29
Section Two: Problem-solving	8	8	90	100	52
Section Three: Comprehension	2	2	40	36	19
			180	192	100

Instructions to candidates

1. The rules for the conduct of Western Australian external examinations are detailed in the *Year 12 Information Handbook 2010*. Sitting this examination implies that you agree to abide by these rules.
2. Write answers in this Question/Answer Booklet.
3. You must be careful to confine your responses to the specific questions asked and to follow any instructions that are specific to a particular question.
4. Working or reasoning should be clearly shown when calculating or estimating answers.
5. Spare pages are included at the end of this booklet. They can be used for planning your responses and/or as additional space if required to continue an answer.
 - Planning: If you use the spare pages for planning, indicate this clearly at the top of the page.
 - Continuing an answer: If you need to use the space to continue an answer, indicate in the original answer space where the answer is continued, i.e. give the page number. Fill in the number of the question(s) that you are continuing to answer at the top of the page.

SEE NEXT PAGE

SECTION ONE: Short Response**56 marks (30%)**

This section has 13 questions. Answer **ALL** questions. Write your answers in the spaces provided. Suggested working time for this section is **54 minutes**.

Question 1**(2 marks)**

The diagram below shows a boat taking shelter from large waves behind a stone barrier. Explain why the boat is still at risk of damage from the waves.

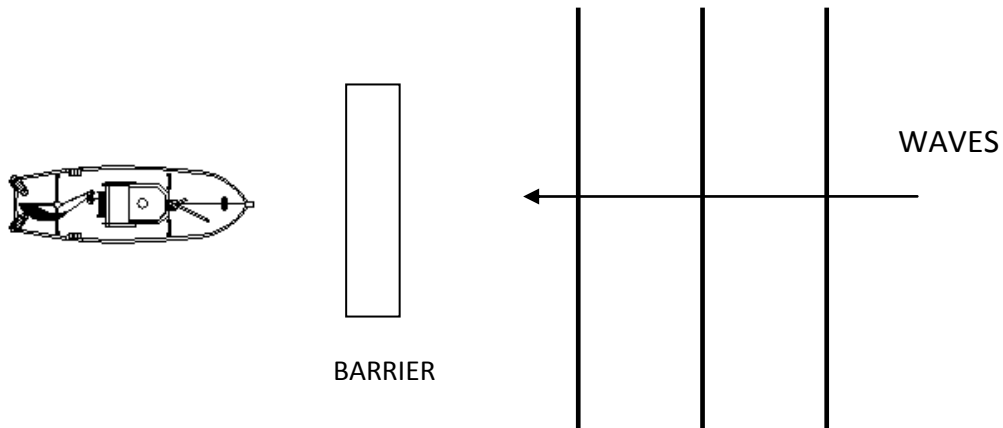
**Question 2****(4 marks)**

Hamish, who has a mass of 65.0 kg, is walking across a high wire suspended between two buildings. The wire makes an angle of 10° to the horizontal where it is attached at either end. Find the tension in the wire.

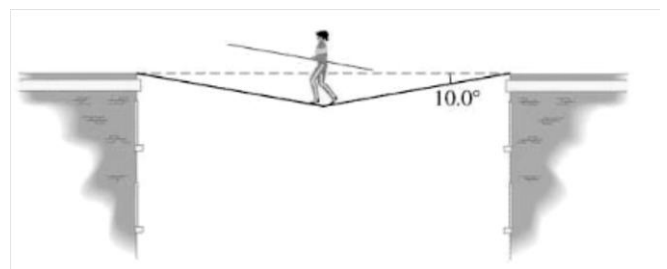
**SEE NEXT PAGE**

Question 3**(4 marks)**

Towards the end of the 20th century scientists suggested that quarks were the basic building blocks of protons and neutrons. Quarks have the following properties:

- They have mass.
- They can have electromagnetic charges of $+1/3$, $+2/3$, $-1/3$, and $-2/3$
- They have colour charge.
- They have spin.

(a) If a proton is made up of 3 quarks, what are the charges on each quark?
(2 marks)

(b) A pi – meson has a charge of $+ 1/3$. It is known to be made up of more than one quark. Suggest its quark composition.
(2 marks)

SEE NEXT PAGE

Question 4**(3 marks)**

Diagram 1 below shows some of the energy levels (measured in electron-volts) of the hydrogen atom. Diagram 2 is a representation of part of the visible spectrum of atomic hydrogen (not to scale).

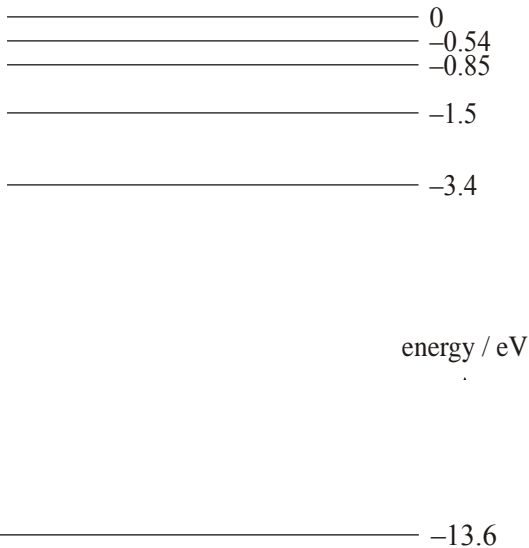
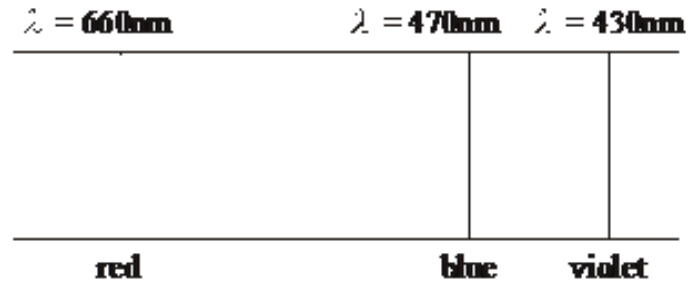
Diagram 1**Diagram 2**

On diagram 1, show with arrows the electron transitions that give rise to the blue and violet lines in the visible spectrum of hydrogen, Label the arrows as **B** and **V** respectively.

Question 5**(4 marks)**

The “observable edge” of the universe is about 12 billion light years away from us.

- (a) How fast, relative to us is a galaxy at this distance travelling? (2 marks)
(Take Hubble’s Constant to be 160 km/sec per millionlight-years)

- (b) Explain why “Hubble’s Law” is evidence that the universe is expanding. (2 marks)

Question 6

(5 marks)

The diagram below illustrates some equipotential lines between two charged parallel metal plates attached to a 100 V battery.

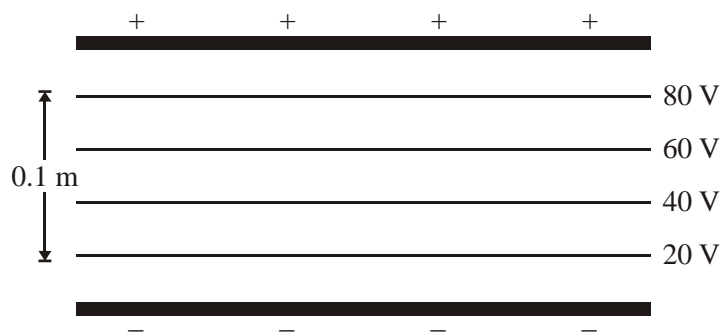

- (a) Calculate the electric field strength between the plates. (2 marks)
- (b) On the diagram, sketch the electric field line distribution between the plates. (1 mark)
- (c) An electron is accelerated from rest across the entire field between the 2 plates. Find its final velocity. (2 marks)

Question 7**(5 marks)**

A model plane of mass 220 g is suspended from a light non-extensible wire of length 1.30 m. When in horizontal circular motion the wire is at an angle of $\theta = 68^\circ$ to the vertical. Calculate the velocity of the model plane. Assume negligible Lift force from the wings of the plane at this speed.

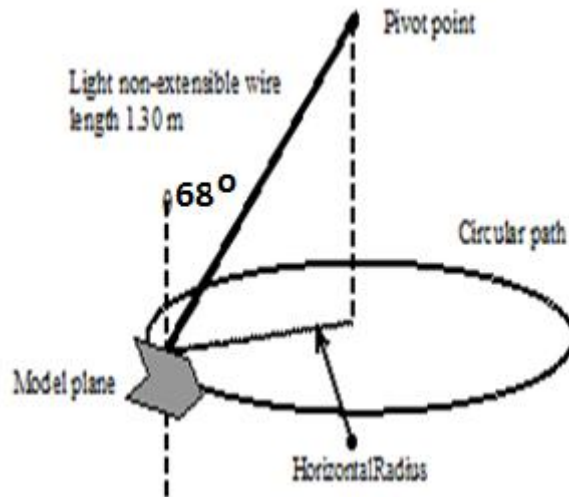

a. Draw arrows on the diagram above to indicate the forces acting on the model plane. (2 marks)

b. Determine the net force acting on the model plane.

(3 marks)

Question 8

(5 marks)

Jane swings from a cliff on a vine rope of length 9.50 m. At the bottom of her swing she has a speed of 13.6 m s^{-1} and can just hold onto the rope. Jane has a mass of 65.0 kg.

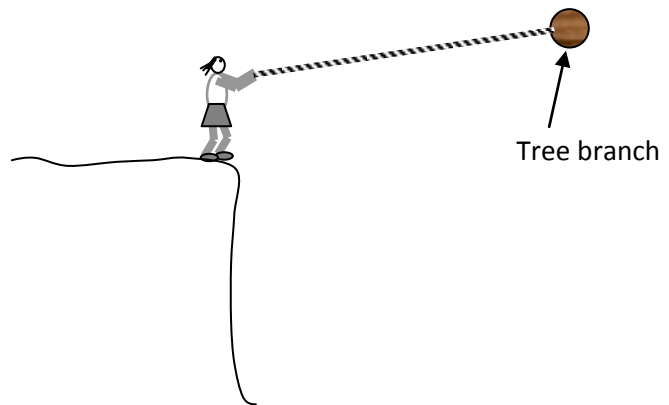

- a. Calculate the centripetal force on Jane at the bottom. (2 marks)

- b. Calculate the Tension force in Jane's arms at the bottom of the swing (3 marks)

Question 9

(6 marks)

2. Look carefully at each diagram and determine the direction of the force.

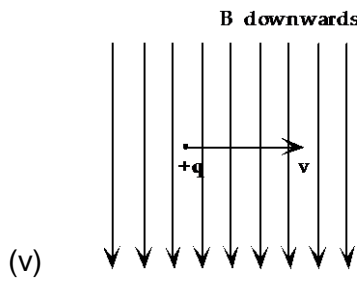
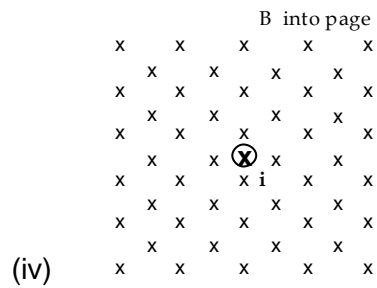
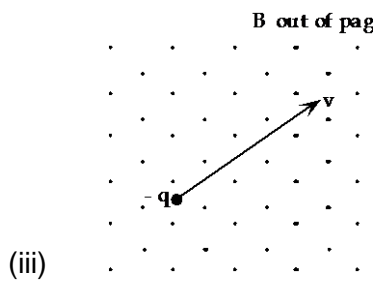
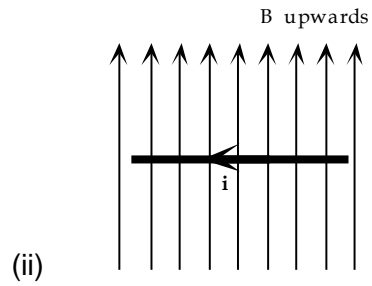
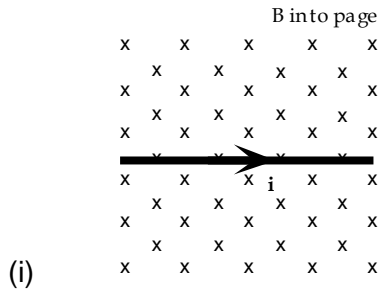

Question 10

(6 marks)

Sophie is traveling on a futuristic bus that is travelling to the right at a constant speed of 90% of the speed of light. The bus travels straight past Eloise who was waiting for another bus. At the instant that the centre of the bus passes Eloise, she notices 2 lightning strikes at either end of the bus.

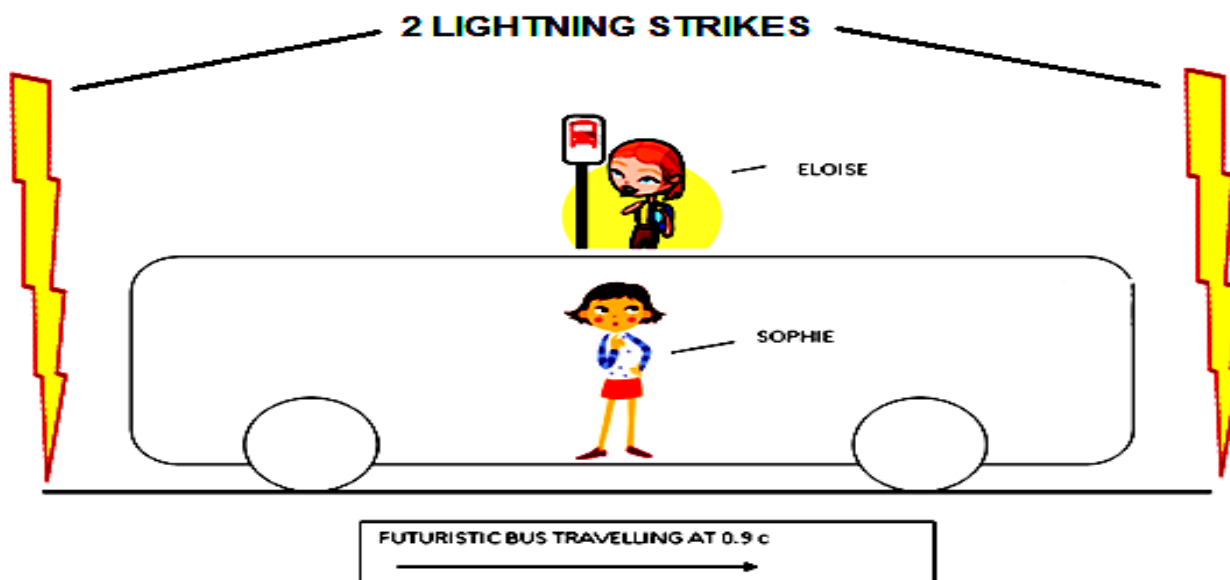

Eloise observes that the 2 flashes of light occurred simultaneously (at the same time).

Eloise thinks that Sophie will see the lightning strike closest to the front of the bus first as the bus is “travelling to meet” the light from the front strike.

In fact Sophie **does** observe the front strike first, but she concludes that the front strike happened before the strike at the back of the bus.

a) Is one girl’s interpretation of the events more correct than the other’s? Explain carefully by making reference to Einstein’s Theory of Special Relativity. (3 marks)

b) How does Sophie explain that the two flashes of light reach Eloise simultaneously? (3 marks)

Question 11**(4 marks)**

A white wooden car is released and allowed to roll down a slope as shown below. The slope is made of aluminium and the car contains a small 50 gram lead mass.

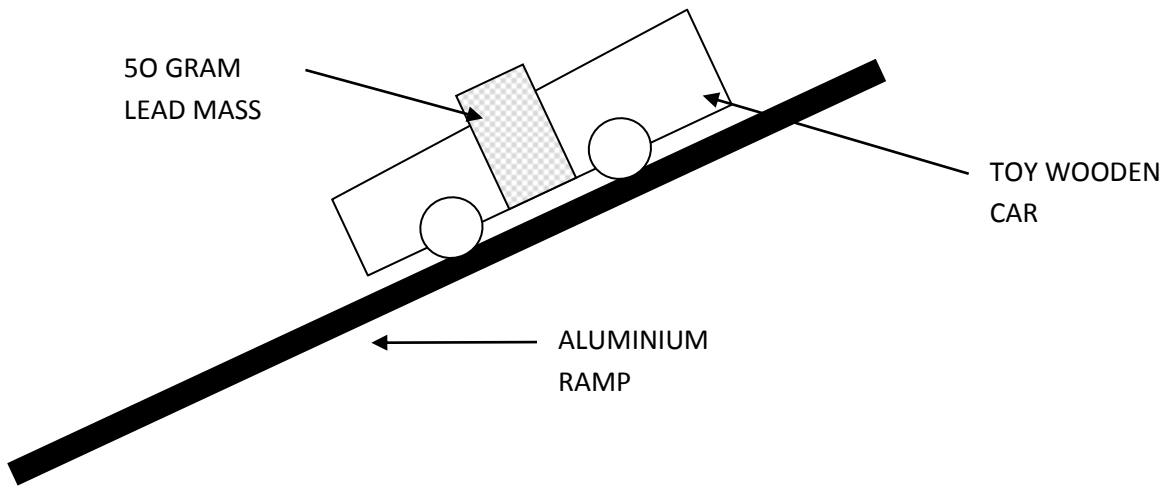

At the same time a similar grey car is released on an identical slope. This car contains a 150 gram steel magnet.

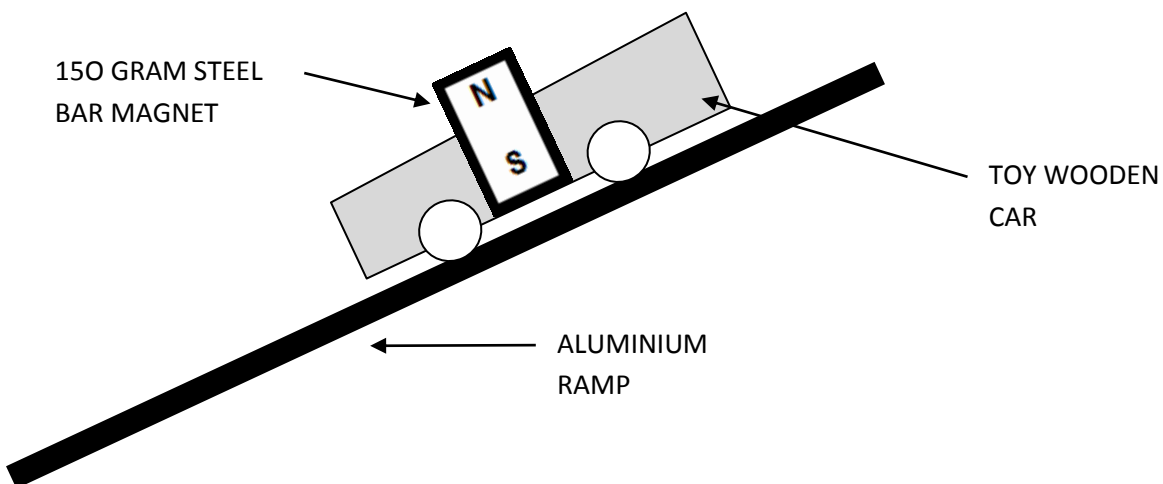

Which car will reach the bottom of its ramp first? Explain using appropriate Physics principles. **You should ignore the effects of friction.**

SEE NEXT PAGE

Question 12

(5 marks)

Graph 1 below shows how displacement (d) of a travelling (progressive) wave varies with time (t).
 Graph 2 shows how displacement (d) of the same wave varies with distance (x).

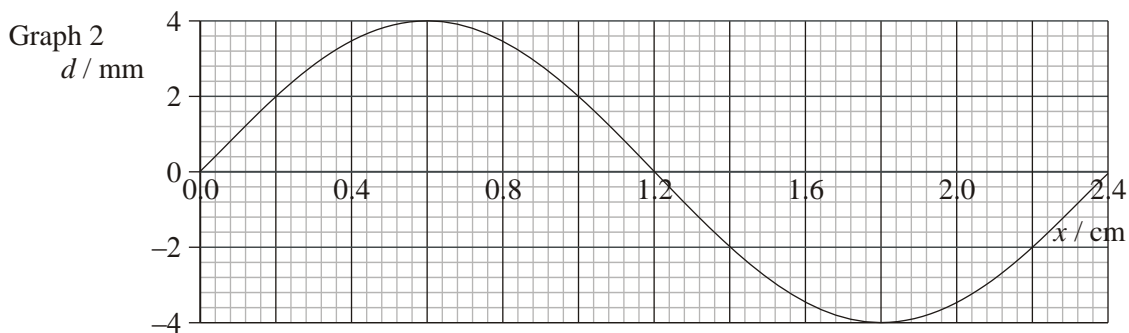
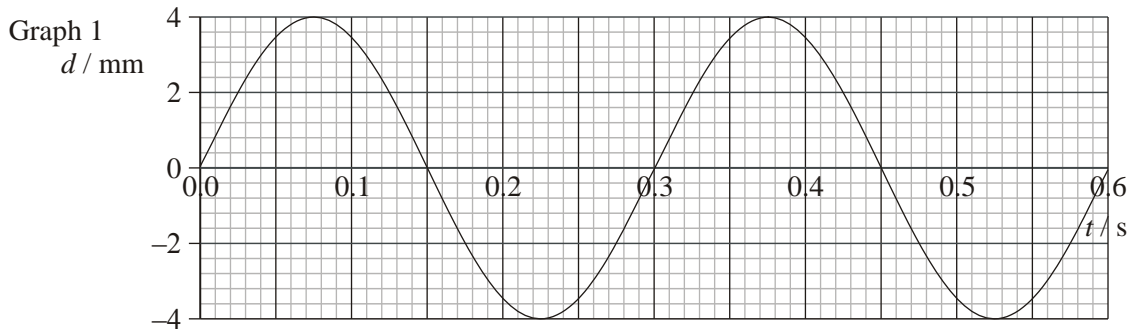

Use the information from the graphs to determine the following properties of the wave?

- (a) Amplitude: _____
- (b) Period: _____
- (c) Frequency: _____
- (d) Wavelength: _____
- (e) Velocity: _____

Question 13**(3 marks)**

Two current carrying conductors are shown in the diagram below.

- (a) Sketch the resultant magnetic field and clearly label any areas of high or low flux density. (2 marks)
- (b) Is there any force between the two conductors? Circle the correct answer below. (1 mark)

There is no force

There is a force of attraction

There is a force of repulsion



End of Section One

SEE NEXT PAGE

SECTION TWO: Problem-solving

90 marks (50%)

This section has **seven (7)** questions. Answer **ALL** questions. Write your answers in the spaces provided. Suggested working time for this section is **90 minutes**.

Question 14

(13 marks)

Light can be produced by exciting electrons within atoms.

- (a) Following excitation, what happens next in order to produce light?

(3 marks)

- (b) Explain by calculating the relevant quantities, whether the excitation required to produce visible light could be achieved by bombarding an atom with electrons that have been accelerated through a potential difference of 240V.

(4 marks)

- (c) The diagram below shows the absorption spectra of the light emitted from the left (spectrum A) and right (spectrum B) sides of the Sun as viewed from Earth. **Note:** 1 Angstrom = 10^{-10} m.

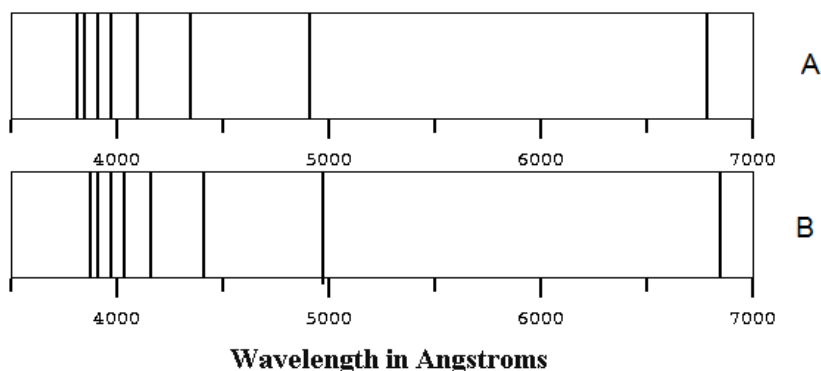

- (d) Scientists use the information in the two spectra as evidence that the Sun is spinning on its axis.
- i. Which spectrum, **A** or **B** shows light that is emitted from the receding side of the Sun?

(1 mark)

- ii. Explain how the lines in the spectra show that one side of the Sun is spinning towards us (approaching), while the other side is spinning away from us (receding).

(2 marks)

- (e) Explain briefly how a line absorption spectrum is formed.

(3 marks)

Question 15

(13 marks)

The diagrams below show a simple electric generator which can convert mechanical energy into electrical energy. A light metal rod, CD, is loaded with a mass M (diagram 1) and is able to slide downward while making contact with two long vertical metal rails PQ and RS. The rods are connected at the bottom by a resistor R , and the whole device is in a uniform magnetic field B perpendicular to the page. (Diagram 1)

When the loaded rod is released from rest, it falls downwards and as a result an electric current, I , flows around the circuit. The rod speeds up initially before reaching a constant downward speed. (Diagram 2)

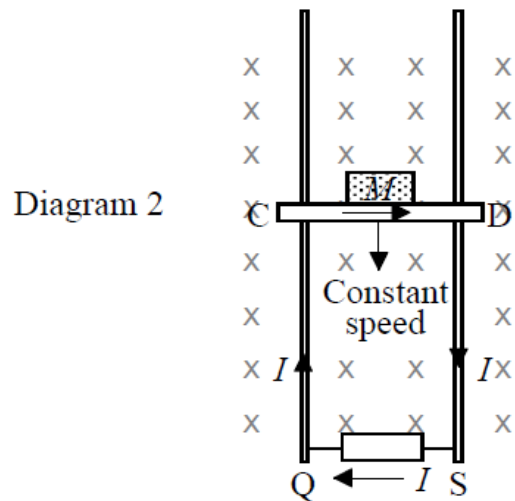
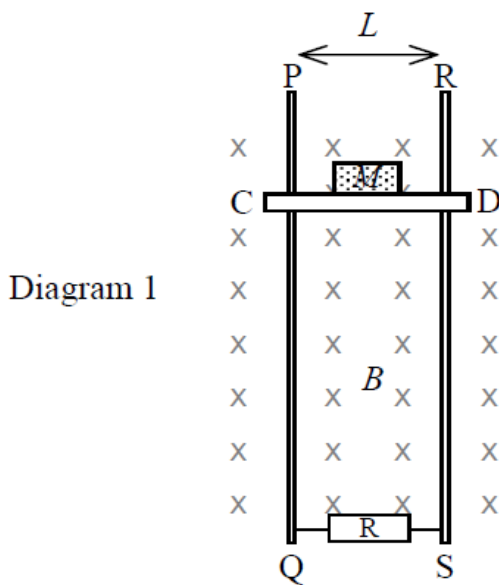

(a) Show on diagrams below, the force(s) acting on the loaded rod just as it is released and when it is falling with a constant speed. Show the forces as **labeled arrows**.

i. Just as it is released

ii. During its fall at constant speed

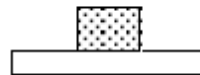

(3 marks)

(b) Explain why the rod accelerates initially and then reaches a constant speed.

(3 marks)

- (c) Derive an expression for the current I flowing through the conductor CD, in terms of L , B , M and g , while the rod is falling at a constant speed (Diagram 2).
Note: g is the acceleration due to gravity (9.80 ms^{-2})

- (d) Using your answer to (c) above and Faraday's Law of Induction: $emf = BvL$, show that the constant velocity attained by the loaded rod CD is: (3 marks)

$$v = \frac{MgR}{B^2L^2}$$

- (e) State a disadvantage of this type of generator compared to a traditional rotational generator. (3 marks)

(1 mark)

Question 16

(14 marks)

A stuntman in a Mission Impossible film needs to jump from a helicopter travelling at a constant 65 ms^{-1} into a car traveling at 25 ms^{-1} in the same direction. He will drop from a point 35 m above the passenger seat of the car, which he will land in.

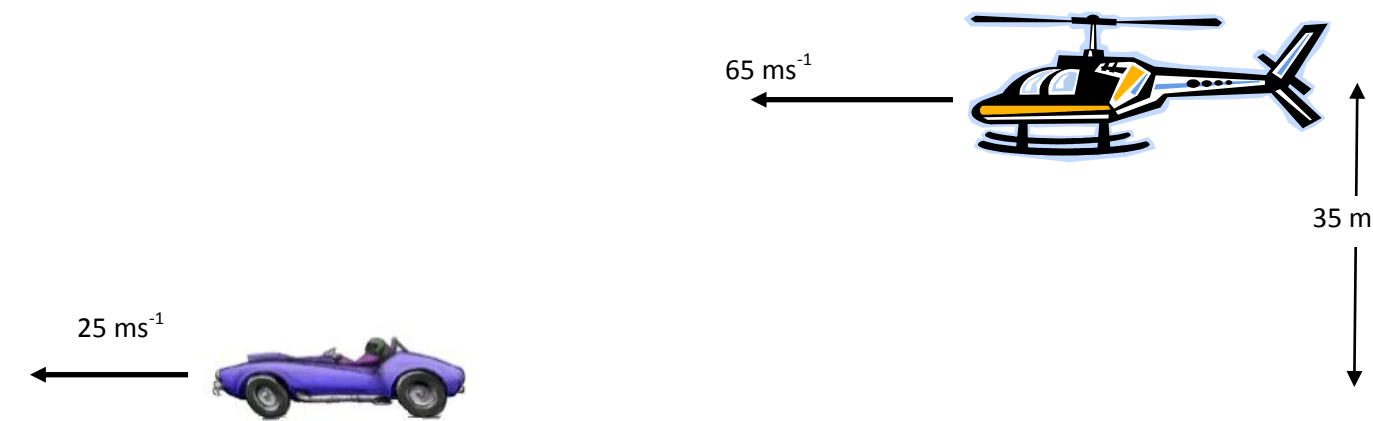

(a) How long does the stuntman take to fall from the helicopter to the car?

(2 marks)

(b) At what distance behind the car should the stuntman make his jump in order to land in the car?
(hint: consider the relative speed between the helicopter and the car)

(2 marks)

(c) At the instant shown in the diagram, the helicopter is 477 m behind the car. How long should the stuntman wait before he makes his jump? (4 marks)

(d) What is the velocity of the stuntman relative to the car when he lands in the car? (4 marks)

(e) Where is the helicopter when the stuntman lands in the car? (2 marks)

Question 17

(11 marks)

A farmer decides to install some solar panels on his property. The site he has chosen is 550 m from his house. The solar system is rated at 4.2 kW and has an output voltage 48 Volts DC when exposed to full summer sun.

He also needs to install an “inverter”, this is an electronic device that converts the 48 V DC voltage to AC and also steps it up to 240 V. The particular inverter used is rated to convert 48 V DC to 240 V AC. This is essential as all of the appliances in the house run on 240 V AC.

The connecting wires from the solar system to his house have a total resistance of 3.0 ohm.

The farmer is not sure whether to install the inverter at the solar panels (configuration A), at the house (configuration B) or if it doesn't matter.

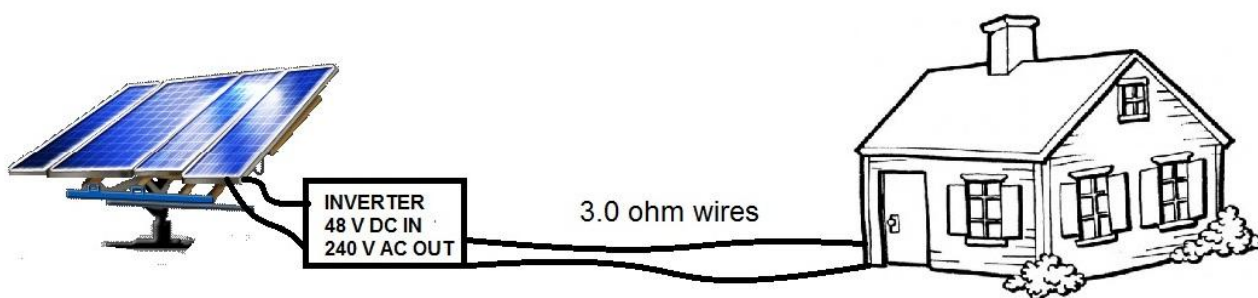

CONFIGURATION A (INVERTER AT SOLAR PANELS)

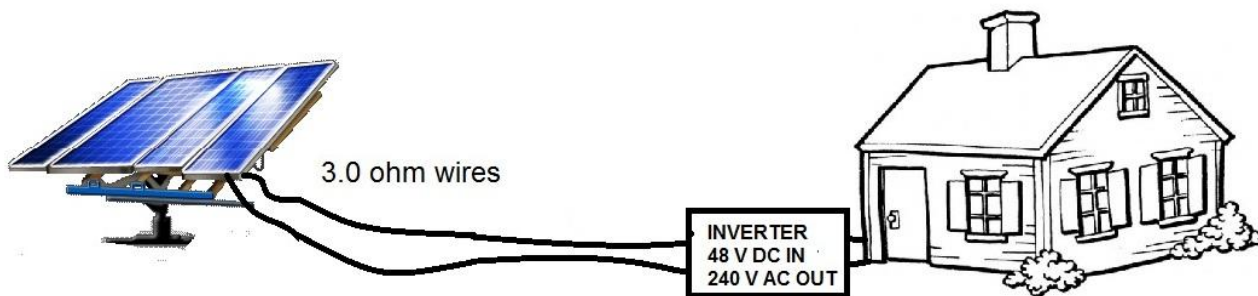

CONFIGURATION B (INVERTER AT THE HOUSE)

(a) What current is flowing in the 3.0 ohm transmission wires for each configuration?

Configuration A:

Configuration B:

(4 marks)

(b) What power is lost in the 0.30 ohm transmission wires for each configuration?

Configuration A:

Configuration B:

(4 marks)

(c) By comparing the percentage efficiencies of the two configurations, make a recommendation to the farmer on which one to use.

(3 marks)

Question 18

(12 marks)

Louise is experimenting with sound in the lab. The diagram below shows a loudspeaker which sends a note of constant frequency towards a vertical metal sheet. As Louise moves the microphone between the loudspeaker and the metal sheet, the reading on sound meter changes several times between maximum and minimum values.

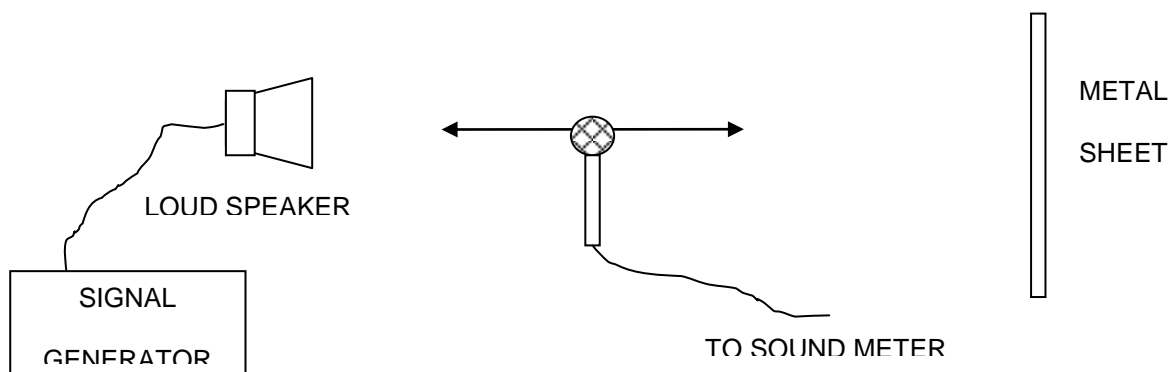

(a) Why did the reading on the sound meter change in the way described?

(4 marks)

(b) For one trial, Louise finds that the distance between two maximum readings is 14.5 cm. What frequency was the speaker emitting during this trial?

(4 marks)

(c) If Louise was to double the frequency supplied in part (b), what would be the distance between two successive points of minimum loudness?

(2 marks)

(d) Louise noticed that the points of minimum loudness were not as loud closer to the metal plate than they were near the speaker. Explain this observation.

(2 marks)

Question 19**(14 marks)**

Consider a stringed musical instrument such as a guitar. The strings can be set in vibration by plucking them. When the string vibrates, the transverse waves travel along the string and are reflected from the fixed ends of the string. These reflected waves then set up standing waves in the string.



- a. Explain what a transverse wave is?

(1 mark)

- b. Explain why standing waves are set up in the string?

(2 marks)

Martha sets up an experiment in order to investigate the relationship between tension in one of the guitar strings and the velocity of the transverse waves in the string. She sets up an apparatus like that shown below and sets it vibrating at a frequency of 60.0 Hz.

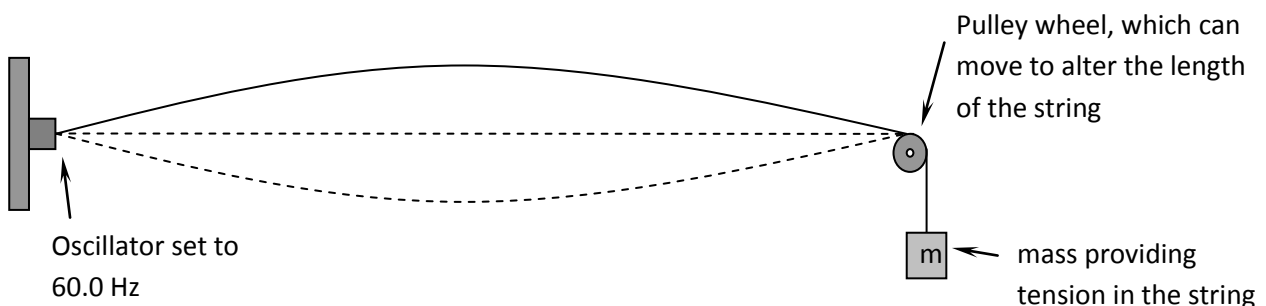
**SEE NEXT PAGE**

From this apparatus she determined the wavelength and tension. Her final averaged results are shown in the table below.

Wavelength, λ (cm)	10.4	14.7	18.0	20.7	23.0	25.8
Tension, F_T (N)	1.00	2.00	3.00	4.00	5.00	6.00
Velocity, v (m s^{-1})						

- c. Complete the row in the table for the velocity of the wave in the string?

(1 mark)

For a stretched string of a given mass per unit length (μ), and under a given tension (F_T), the velocity (v) of a wave in the string is given by the following equation:

$$v = \sqrt{\frac{F_T}{\mu}}$$

- d. Explain how you could modify the data in the table so that you can plot a straight-line graph to show the relationship between velocity and tension.

(3 marks)

- e. Now modify the data in the table above. Some blank rows have been provided for you.

(1 mark)

- f. Using the graph paper below, plot the straight-line graph.

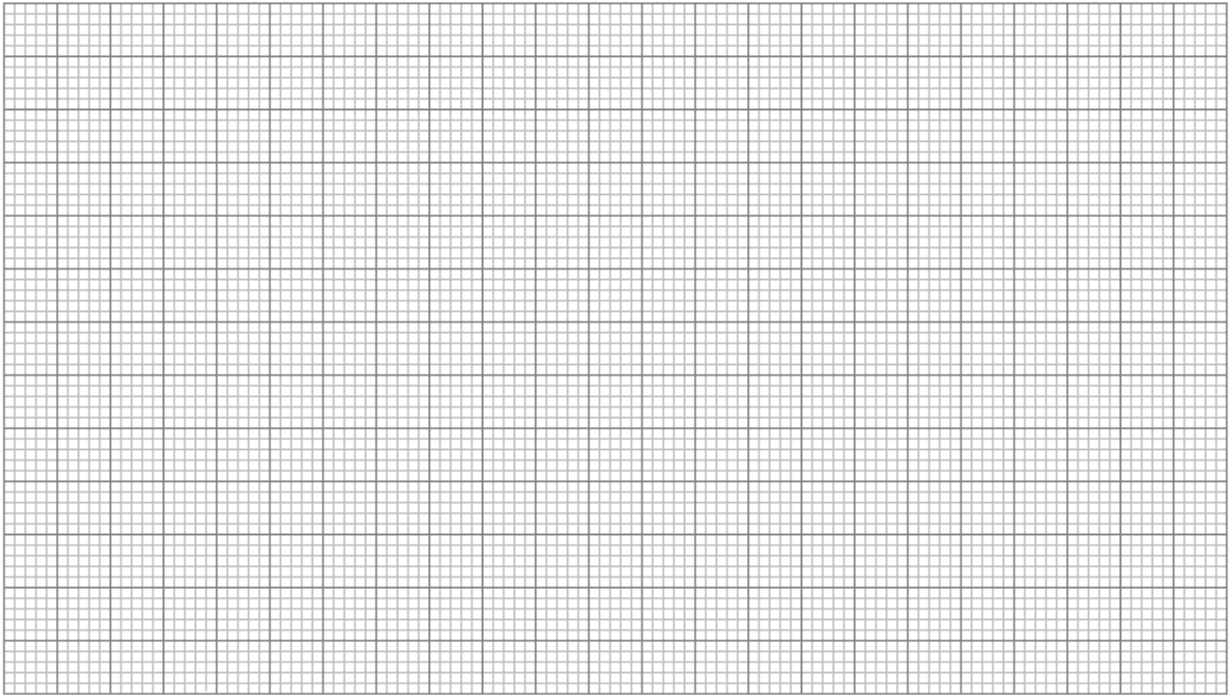

(3 marks)

- g. **Using the graph you have drawn**, determine the mass per unit length (μ) of the guitar string.

(3 marks)

SEE NEXT PAGE

Question 20

(12 marks)

The diagram to the right shows a 25.5 kg traffic light suspended from the end of a 15.0 kg, 7.50 m uniform aluminium pole AB.

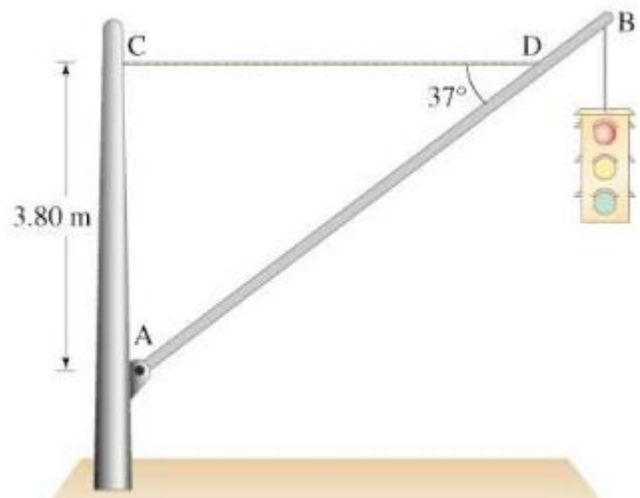

- (a) Draw a free body diagram of the pole (AB), showing all forces acting on it.

(4 marks)

- (b) Find the tension in the horizontal cable (CD).

(4 marks)

- (c) Find the size and direction of the reaction force exerted on the pole AB, by the hinge at A.

(4 marks)

Question 21**(10 marks)**

Barnard's star is a red dwarf (ex-star) that has 17% of our Sun's mass and 15% of our Sun's diameter. Barnard's star still radiates heat (and light), but is much cooler than our own Sun.

For Barnard's star to have a planet with liquid water at its surface, the planet would need to be quite close to the star's surface. According to astronomers, a suitable distance would be 0.06 AU. Such a planet is said to be in the "Habitable Zone". Note one AU (astronomical unit) and is the distance between the Earth and our Sun.

- (a) Determine the time, in weeks, that it would take a planet in the habitable zone to orbit Barnard's Star.

(4 marks)

- b. Barnard's star is in the constellation Ophiuchus and has a parallax angle of 0.549 arc-second as measured from Earth. When a star is viewed from two positions where the earth is 1 AU on either side of the sun the angle between the two observation lines is used to calculate the parallax angle.

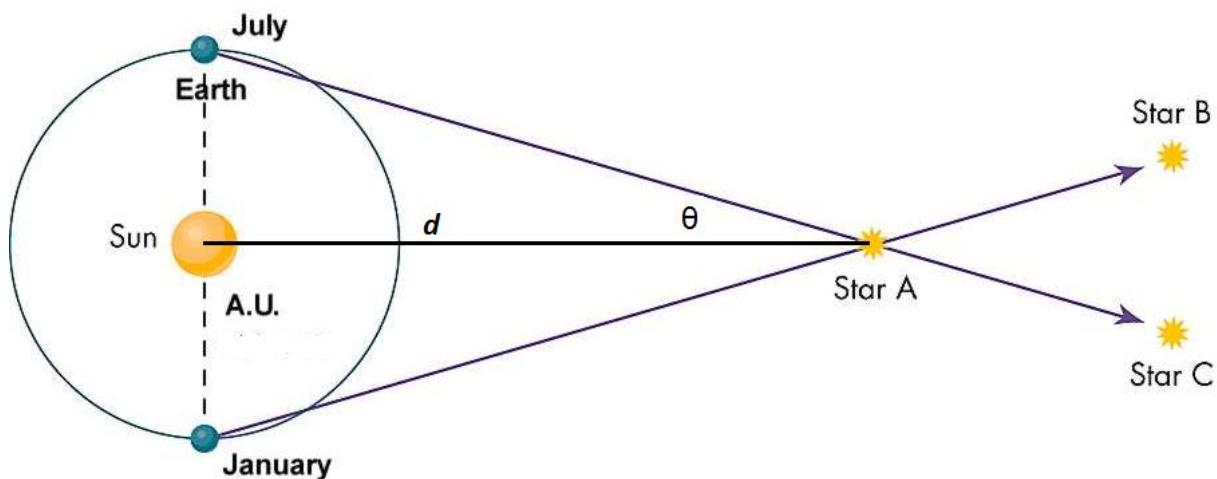

- (i) If the parallax angle θ is 1 arcsecond (2.7×10^{-4} degrees) then determine the distance d in the diagram (which is equal to 1 parsec).
(3 marks)

- (ii) Find the distance from Barnard's Star to our Sun in metres if the parallax angles 0.549 arcseconds.

(3 marks)

End of Section Two

SEE NEXT PAGE

THIS PAGE HAS BEEN LEFT BLANK INTENTIONALLY

SEE NEXT PAGE

SECTION THREE: Comprehension and data analysis**36 marks (20%)**

This section contains **two (2)** questions. You must answer both questions. Write your answers in the spaces provided. Suggested working time for this section is **40 minutes**.

Question 22**(18 marks)****The Cyclotron**

In most capital cities in Australia large modern hospitals have a department where radioisotopes are produced on demand by using a particle accelerator called a cyclotron.

The system uses a powerful magnetic field provided by an electromagnet directed vertically downward in two semicircular regions called Dees as in the diagram below. While a proton is moving in these D shaped regions of the field it will move along a circular arc. It will be accelerated by the magnetic field but it will not gain any speed while moving through the Dee.

The two Dees are separated by a rectangular shaped region of space occupied by a uniform electric force field. This is produced by an alternating current source attached to two parallel plates. This force field is essential to give the proton an increase in kinetic energy. The frequency with which this AC source reverses polarity must also be changed as the proton moves through each section of its motion.

In our example below the accelerating Voltage between these plates is set to 1000Volts. A proton introduced in the middle of this cyclotron with zero velocity crosses the Electric Force field 6.5 times before it finally is directed down a metal tube at the end of which it will collide with the isotope in the target.

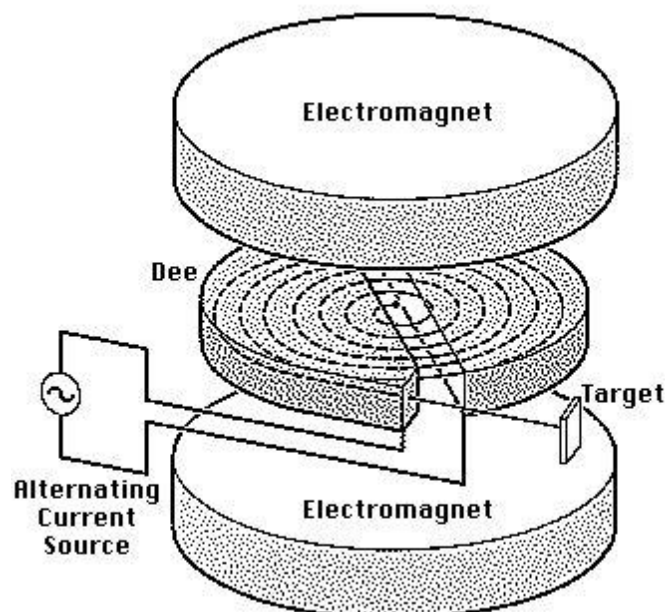
**SEE NEXT PAGE**

(a) .Explain why the proton increases speed as it crosses the electric force field.

(2 marks)

(b) .Explain why the proton does **not** increase in speed as it crosses the magnetic force field regions.

(2 marks)

(c) Calculate the gain in E_k experienced by the proton after it has crossed the electric force field 6.5 times. Show your working.

(3 marks)

(d) Explain why the radius of the motion of the proton increases from one Dee to the next.

(3 marks)

(e) Why is it essential to have an AC accelerating voltage.

(2 marks)

SEE NEXT PAGE

- (f) Why is it necessary to increase the frequency of the AC voltage as the electron does its laps around and around in the field.

(3 marks)

- (g) There are limitations to the voltage that can be used in this design of cyclotron. If the voltage used is too high the proton stream may wander off course and crash into the sides of the Dee. Luckily only low kinetic energy protons are necessary to generate the radioisotopes needed by the hospital technicians. Explain why these extremely high kinetic energy protons would go “out of control” in their motion.

(3 marks)

Question 23 WHAT IS THE UNIVERSE MADE OF?**(18 marks)**

Adapted from: *Science News*, 23/04/2011, Vol. 179 Issue 9, p24-25 by Alexandra Witze

Read the article and then answer the questions that follow.

In ancient times, listing the ingredients of the universe was simple: earth, air, fire and water. Today, scientists know that naming all of that, plus everything else familiar in everyday life, leaves out 95 percent of the cosmos's contents'.

From the atoms that make up an astronomer, to the glass and steel of a telescope, to the hot plasma of the stars above -- all ordinary stuff accounts for less than 5 percent of the mass and energy in the universe. "All the visible world that we see around us is just the tip of the iceberg," says Joshua Frieman, an astrophysicist at the University of Chicago and the Fermi National Accelerator Laboratory in Batavia, Ill.

The rest is, quite literally, dark. Nearly one-quarter of the universe's composition is as-yet-unidentified material called dark matter. The remaining 70 percent or so is a mysterious entity known as *dark energy* that pervades all of space, pushing it apart at an ever-faster rate.

A different matter

Dark matter made its debut in 1933, when Swiss astronomer Fritz Zwicky measured the velocities of galaxies in a group known as the Coma cluster and found them moving at different rates than expected. Some unseen and large amount of "dunkle Materie," he proposed in German, must exist, exerting its gravitational effects on the galaxies within the cluster.

Astronomer Vera Rubin confirmed dark matter's existence in the 1970s, after she and colleagues had measured the speeds of stars rotating around the centres of dozens of galaxies. She found that, counter intuitively, stars on the galaxies' outer fringes moved just as rapidly as those closer in - as if Pluto orbited the sun as quickly as Mercury. Rubin's work demonstrated that each galaxy must be embedded in some much larger gravitational scaffold.

The leading candidate for a dark matter particle is the vaguely named "weakly interacting massive particle," or WIMP. Such particles would be "weakly interacting" because they rarely affect ordinary matter, and "massive" because they must exceed the mass of most known particles, possibly weighing in at as much as 1,000 times the mass of the proton. But nobody has yet definitively detected a WIMP, despite decades of experiments designed to spot one.

Mysterious forces

Spotting dark matter may prove to be easier than understanding dark energy, whose mysteries make scientists feel like mental wimps.

Albert Einstein unknowingly ushered dark energy onto the stage in 1917, while modifying his new equations of general relativity. Einstein wondered why gravity didn't make the universe contract in on itself, like a balloon with the air sucked out of it. In 1929, though, Edwin Hubble solved Einstein's problem by reporting that distant galaxies were flying away from each other. The universe, Hubble showed, was expanding. It had been zooming outward ever since the Big Bang gave birth to it. Something funny was going on, giving the cosmos a repulsive push. So in 1998 Michael Turner, a cosmologist at the University of Chicago, dubbed the thing "funny energy" at first, before settling on "dark energy."

SEE NEXT PAGE

- a) According to the article, all matter that we can observe makes up only 5% of the content of the Universe. What constitutes the other 95%?

(2 marks)

- b) What observations did Fritz Zwicky make for him to theorise about the presence of "dunkle Materie" (translates to "Dark Matter" in English)?

(2 marks)

- c) How did Vera Rubin confirm the existence of dark matter in 1970?

(4 marks)

- d) Astronomers have theorized the existence of WIMPS (weakly interacting massive particles). Why do astronomers believe the particles must be massive?

(2 marks)

- e) In 1917, Einstein pondered the fact that the Universe doesn't contract in on itself. Why do you think Einstein would have expected the Universe to contract?

(2 marks)

- f) Why is the concept of "Dark Energy" necessary for our current understanding of astronomy?

(2 marks)

- g) Our galaxy, the Milky Way contains approximately 300 billion stars. Assuming that our solar system is 26,000 light years from the centre of the galaxy, estimate the amount of mass that would need to be present at the centre of the galaxy (excluding the possibility of dark matter) for our sun to orbit the centre of the galaxy once every 225 million years.

(4 marks)

End of Questions
SEE NEXT PAGE

